

FÖRDERBAND

CONVEYOR

TAPIS CONVOYEUR

TRANSPORTBAND



Art. Nr. 190276/1

D

Vor Beginn des Bastelns sollten Sie sich mit den Spritzlingen und der Anleitung vertraut machen. Sollte es einmal vorkommen, dass ein Teil im Bausatz fehlt, kreuzen Sie bitte das fehlende Teil in der Anleitung an und schicken Sie diese bitte an Fa. Gebr. FALLER GmbH, Abt. Kundendienst, kundendienst@faller.de, Kreuzstraße 9, 78148 Gütenbach. Sie erhalten dann umgehend Ersatz. Es kann vorkommen, dass bei einem Bausatz Einzelteile übrig sind.

GB

Before beginning with the assembly please familiarize yourself with the parts and read the instructions carefully. In case of missing parts please indicate these on the instructions leaflet with a circle and return the leaflet to Gebr. FALLER GmbH, kundendienst@faller.de, Kreuzstraße 9, D-78148 Gütenbach, Germany. You will receive the replacement by return. It may happen in a kit that some parts are not required.

F

Avant de commencer le montage de votre maquette bien lire la notice et repérer les grappes. Si une pièce manque dans une boîte, cochez la pièce correspondante sur la notice et renvoyez-la-nous à Gebr. FALLER GmbH, kundendienst@faller.de, Kreuzstraße 9, D-78148 Gütenbach (R.F.A.). Nous vous ferons parvenir la pièce par retour. Dans certains kits, il est possible que certaines pièces ne soient pas utilisées.

NL

Vóór het bouwen zou men de gietstukken en de handleiding moeten bestuderen. Indien onverhoopt een onderdeel aan het bouwpakket ontbreekt, gelieve men het ontbrekende deel in de handleiding aan te kruisen en deze te zenden aan Gebr. FALLER GmbH, kundendienst@faller.de, Kreuzstraße 9, D-78148 Gütenbach. U ontvangt dan omgaand en gratis het ontbrekende onderdeel. Het kan voorkomen dat u bij bepaalde bouwdozen onderdelen overhoudt.

Für den Zusammenbau des Modells empfehlen wir folgende FALLER-Artikel (sind nicht im Bausatz enthalten):

For the assembly of the kit we recommend following FALLER products (not included in the kit):

Pour l'assemblage du modèle, nous vous recommandons les articles FALLER suivants (non inclus dans le kit):

Om dit model te bouwen adviseren wij de volgende FALLER producten (maken geen deel uit van deze bouwset):

Art. Nr. 170492
FALLER-EXPERT

Flüssigkleber in Plastikflasche mit Spezialkanüle für feinste Klebstoffdosierung.

Liquid cement in plastic bottle with canule for very fine dosage.

Colle liquide en bouteille plastique avec bec verseur pour un dosage précis.

Vloeibare lijm in plastic flescon met doseerbuisje om nauwkeurig te lijmen.



Art. Nr. 170688
SPEZIAL-SEITENSCHNEIDER

zum geratfreien Abtrennen von feinsten Spritzteilen.

Nur für Polystyrol geeignet.

Special side cutter for cutting off ultra-fine moulded parts without burrs. Only suitable for polystyrene.

Pince coupants spéciale pour couper sans bavure les pièces miniatures moulées par injection. Convient uniquement au polystyrène.

Speciale zijknijplang voor het burmloos afknippen van de fijnste gietstukdelen. Alleen geschikt voor polystyrol.

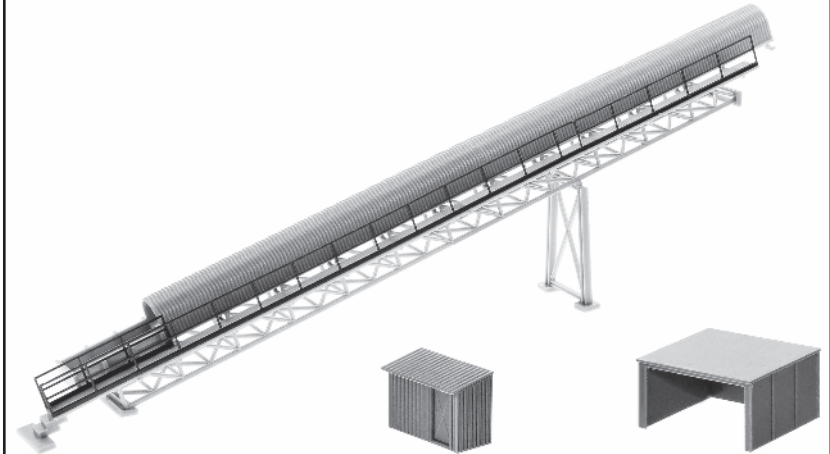

Inhalt	Spritzlinge	3 C	1 x
Contents	Sprues	6 A	2 x
Contenu	Moulages	7 C	1 x
Inhoud	Gietstukken		

Sa. Nr. 129 523 0

2

Durch die Formgebung der Trapezblech-Struktur kann es vorkommen, daß manche Teile leicht verzogen sind.
In diesem Fall mit einem Haartrockner leicht erwärmen und vorsichtig grade biegen.

Owing to the shape given to the structure with trapezoidal corrugations, it is possible for some parts to be slightly deformed.
In such a case slightly heat them using a hair-drier, and cautiously straighten them.

En raison de la forme donnée à la structure à tôles trapézoïdales, il peut arriver que quelques pièces soient légèrement déformées.
Dans un tel cas, les chauffer légèrement à l'aide d'un sèche-cheveux et les redresser avec prudence.

Door de trapeze blik structuur kan het voorkomen dat sommige onderdelen licht vervormd zijn.
In dat geval met een haarföhn iets verwarmen en voorzichtig recht buigen.
De onderdelen precies uitsnijden en ontbramen.

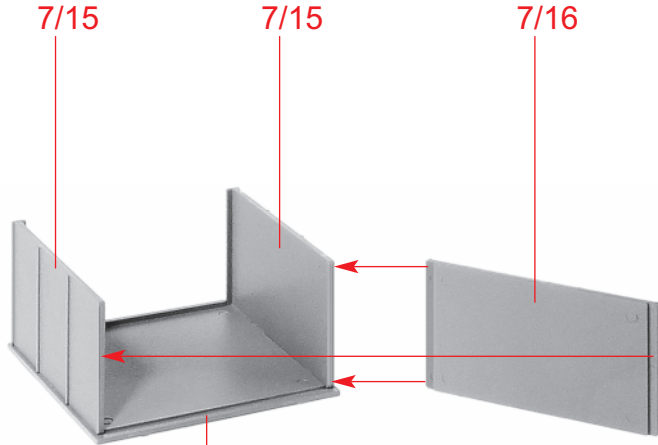

A

7/17

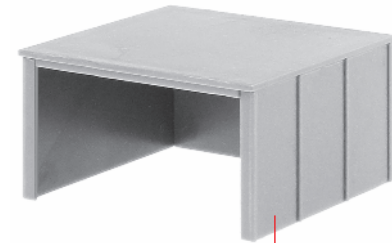

B

A

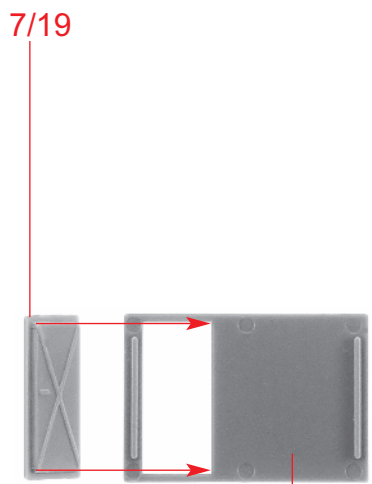

C

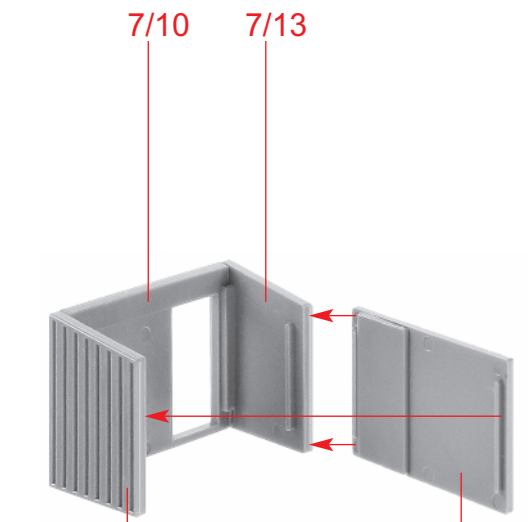

D

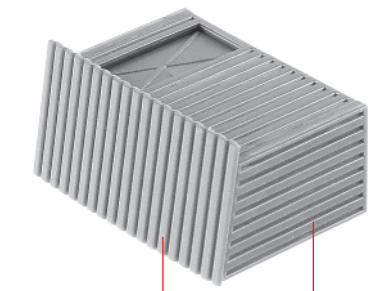

E

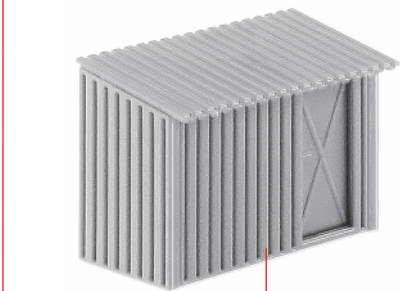

F

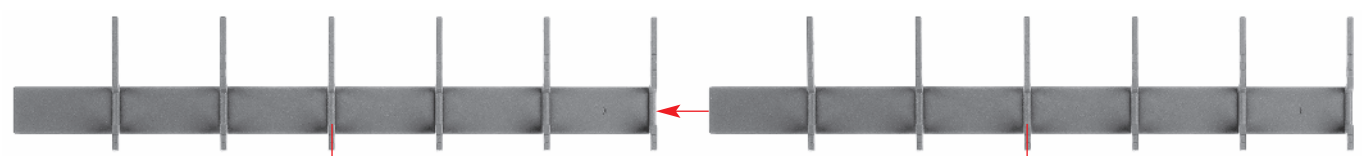

G

6/1

6/1

4

Die Teile sauber ausschneiden und entgraten.
Cleanly cut out the parts and deburr them.
Découper proprement les pièces et les ébarber.
De onderdelen precies uitsnijden en ontbramen.

6/2

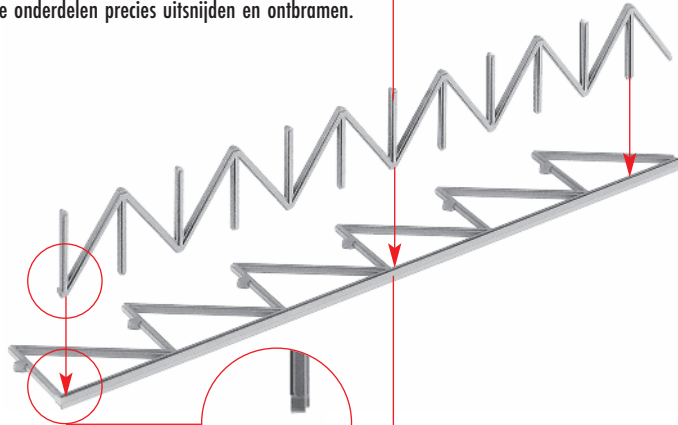

H 2 x

6/3

6/17

6/3

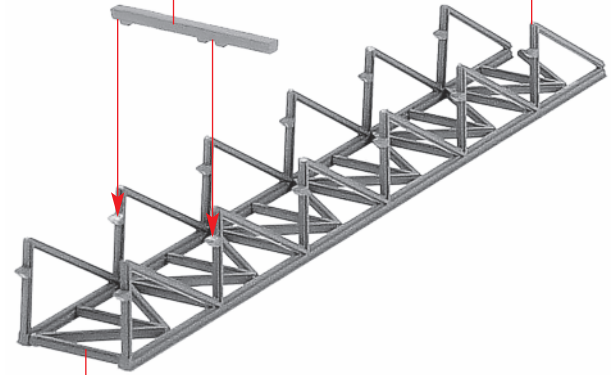

I

H

6/3

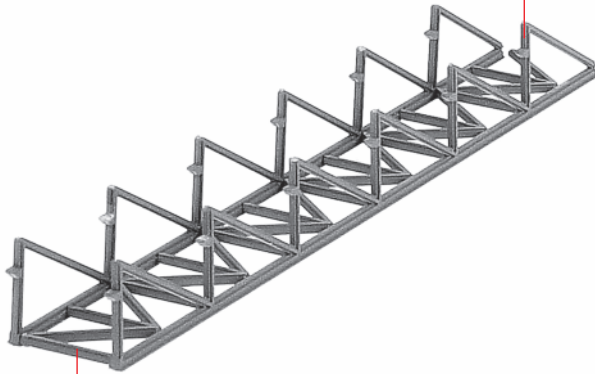

J **H**

I

J

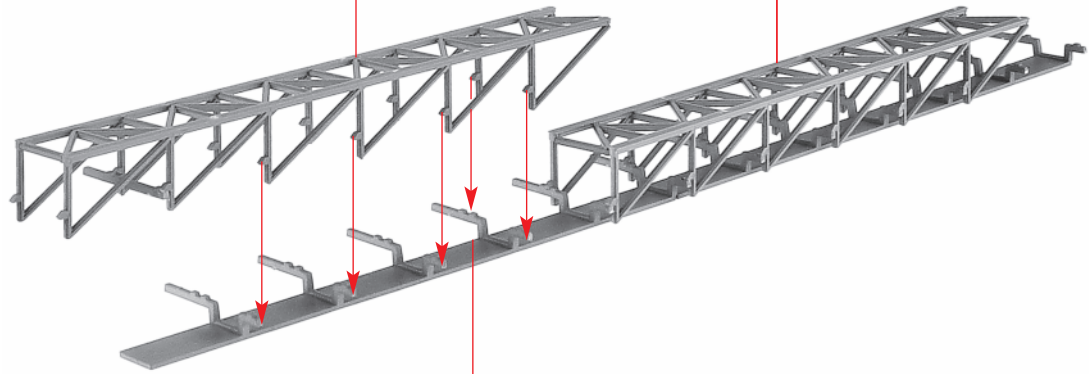

K

G

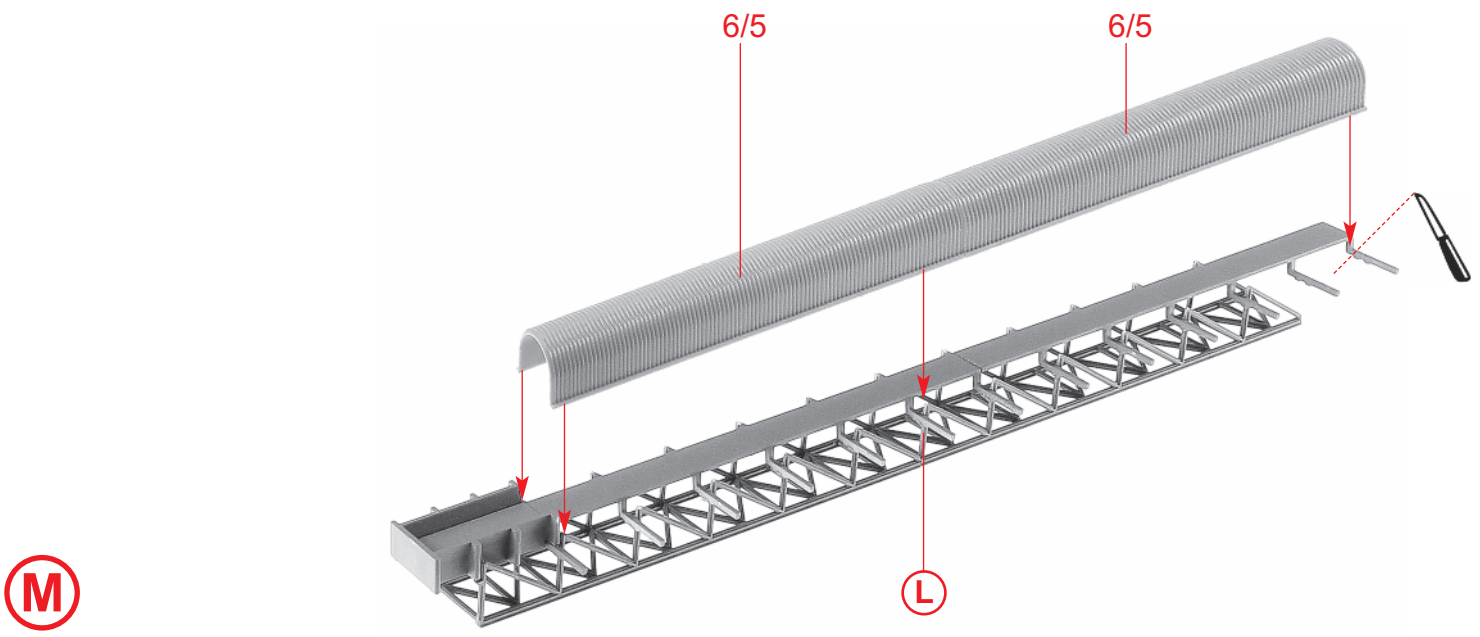
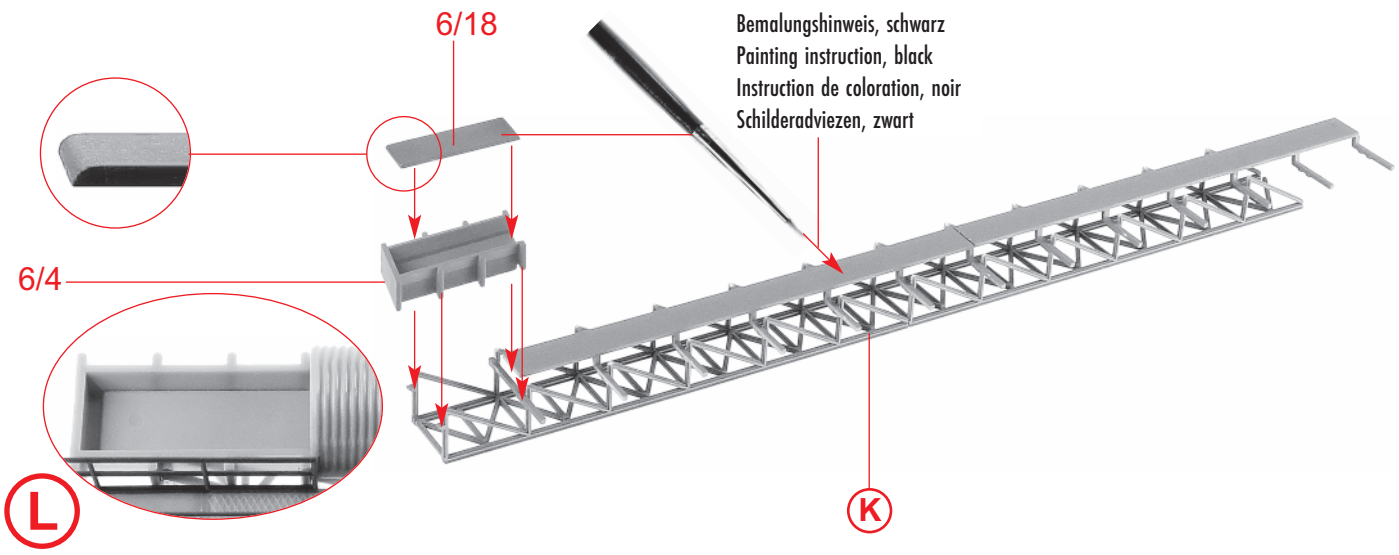

6

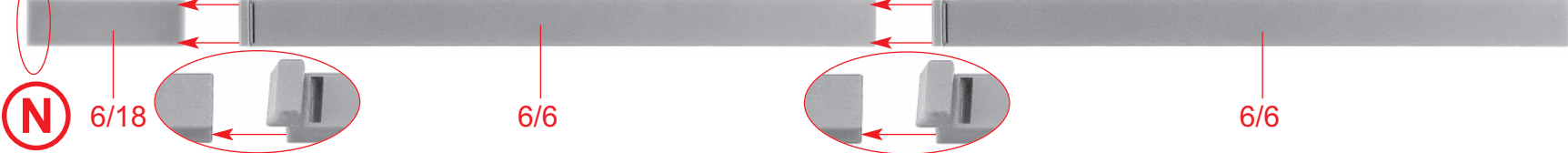
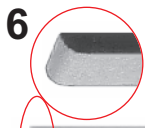

N

6/18

6/6

6/6

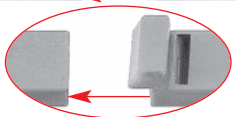
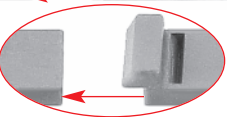

3/4

O

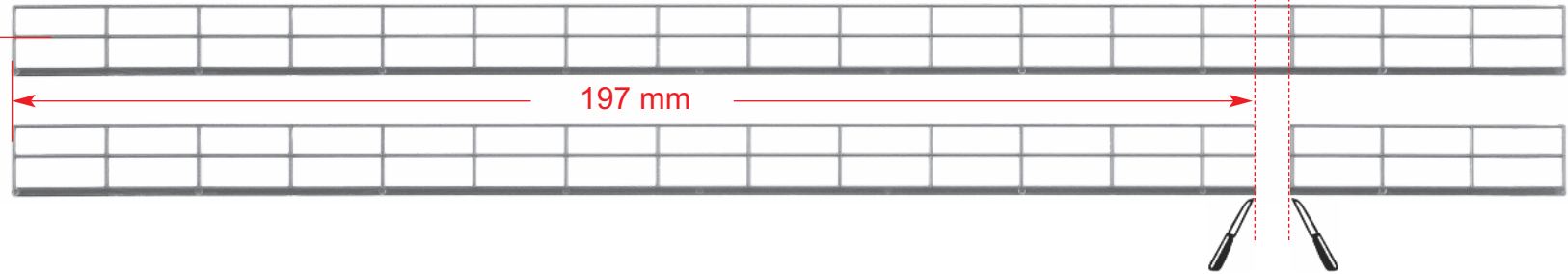

197 mm

3/5

P

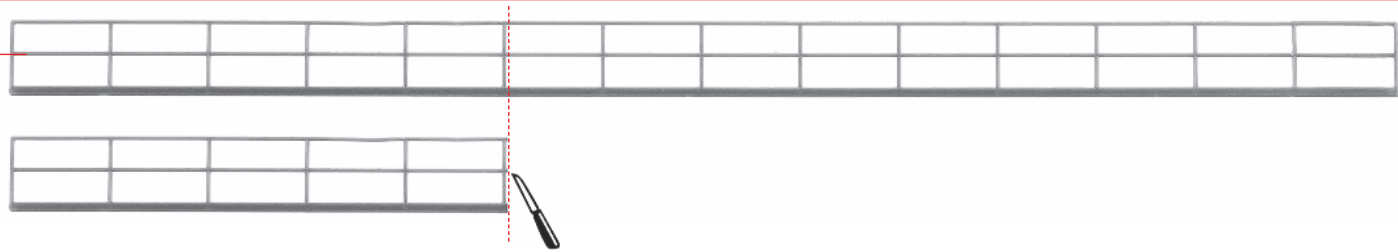

Q

N

O

P

197 mm

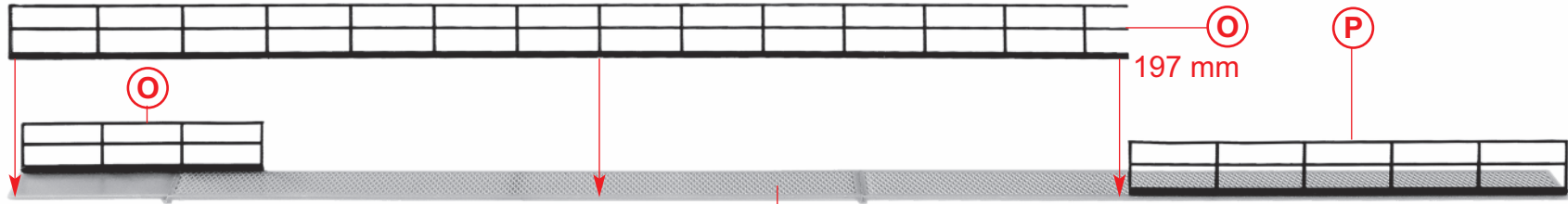

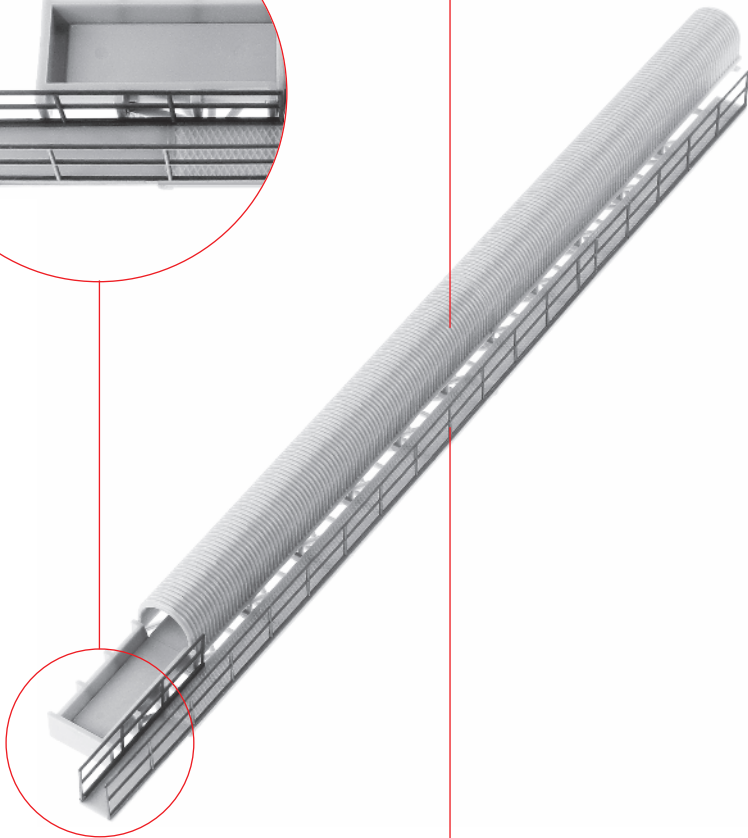
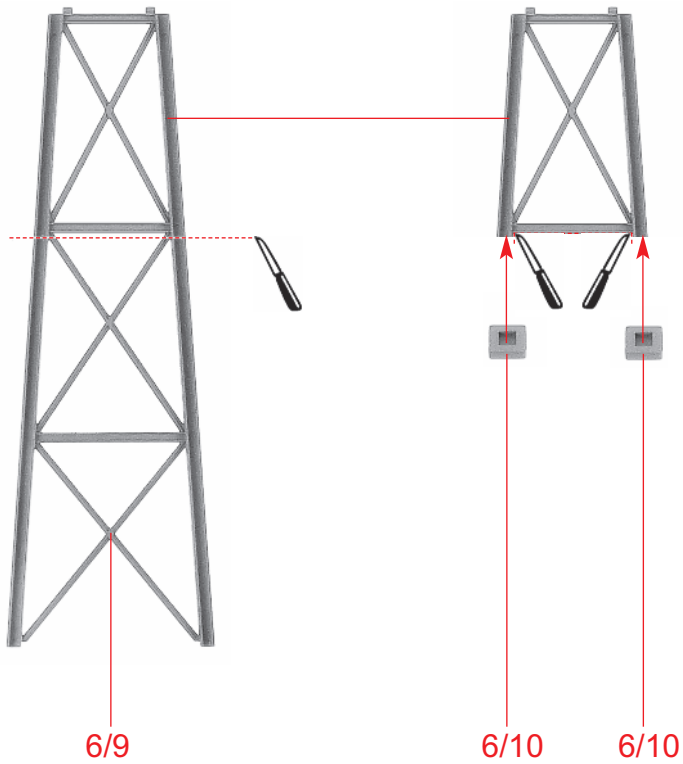
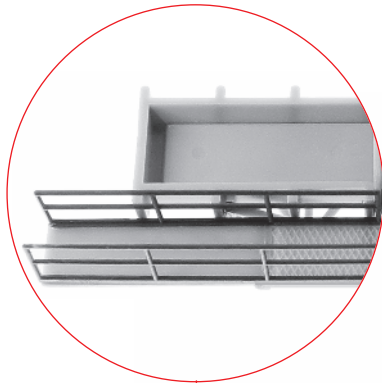
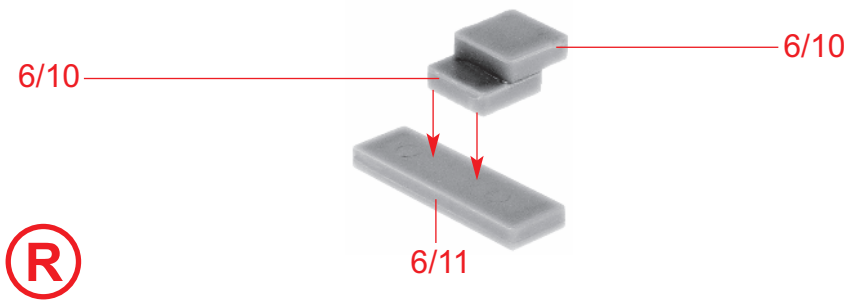

8

6/7

Art. Nr. 190276/03

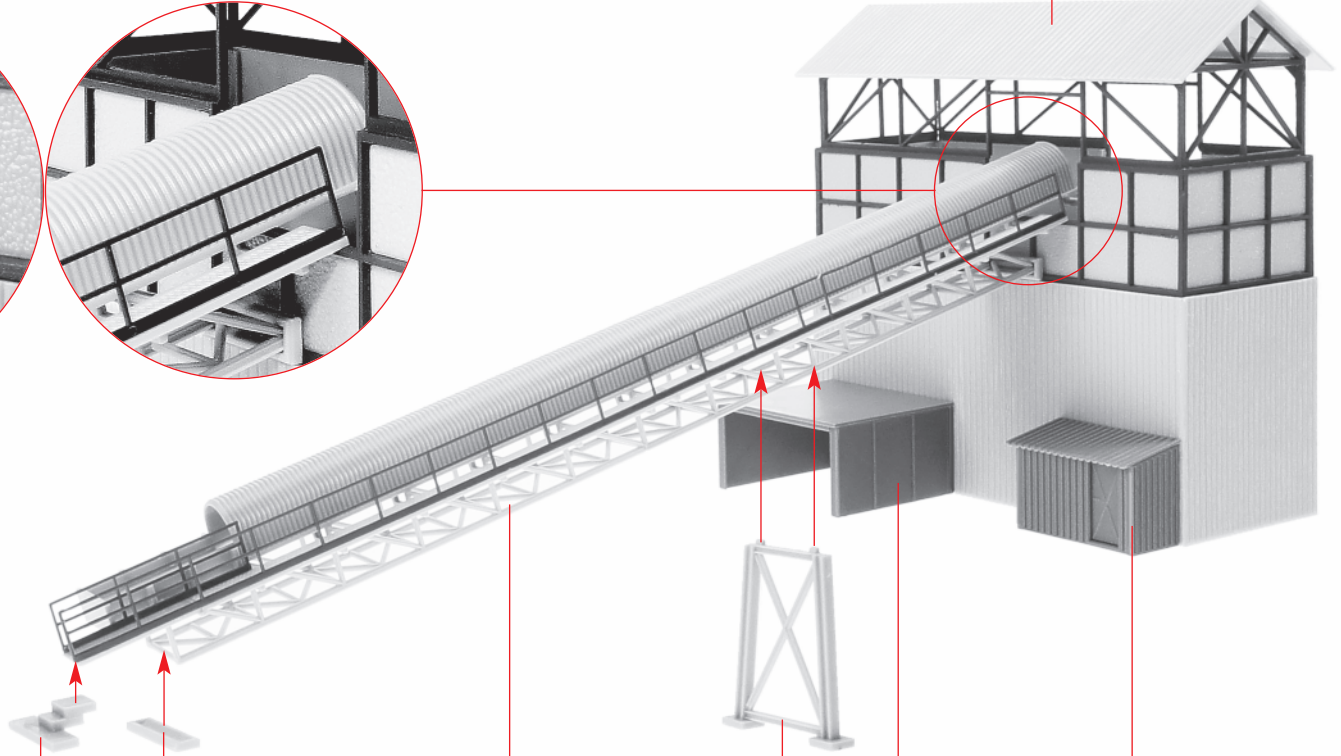
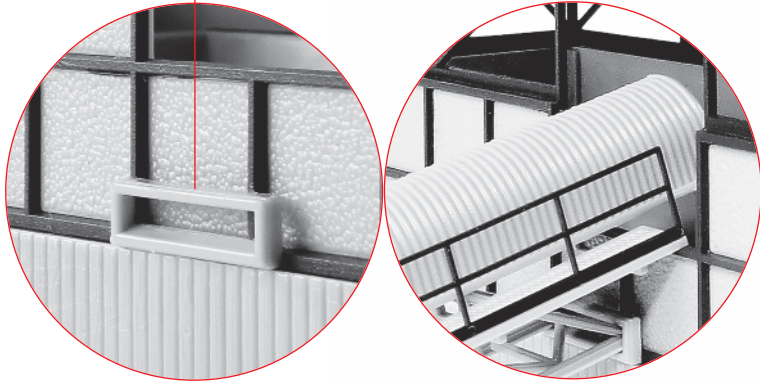

U

R

6/11

T

S

B

F